

# CAT<sup>®</sup> Articulated Dump Truck Centralized Lubrication System



## Installation

Instructions for installing a Graco automatic lubrication system on the CAT Articulated Dump Truck Models 725 to 745.



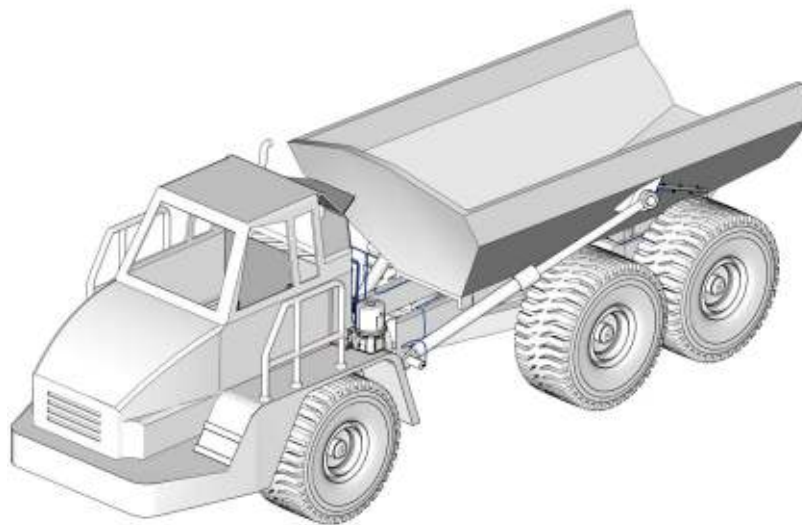

*Maximum System Working Pressure: 3000 psi (20.68 MPa, 206.8 bar)*



### Important Safety Information

Before beginning any installation, read all warnings and instructions in all related Graco component manuals (page 25) and all related Original Equipment Manufacturer (OEM) manuals, including the vehicle's Operation and Maintenance Manual (OMM). Save all instructions.

The lubrication system design described in this manual is based upon representative equipment models. Models may vary slightly depending on series and year. Additional hoses, fittings, and valve outlet doubling plugs are supplied with the kits to modify the system based on your model's specific configuration.

 <b>WARNING</b>			
			
<p><b>FLUID INJECTION HAZARD</b></p> <p>Fluid leaks from incorrectly installed or ruptured components, and/or failure to verify the components are properly installed and tested, can result in serious injury such as fluid spraying in the eyes or on skin and fluid injection, or equipment damage.</p>			

NOTICE
<p>Welding can damage electronics and the equipment's structure. To help prevent equipment damage caused by welding:</p> <ul style="list-style-type: none"> <li>• Disconnect the vehicle battery before welding.</li> <li>• Follow all welding guidelines in the OEM manuals, including the OEM service manuals.</li> <li>• Only weld in locations specifically approved by the OEM. Consult OEM dealership for information and recommendations.</li> <li>• Perform all welding in accordance with American Welding Standard (AWS) standards.</li> </ul>

*The installation instructions contained in this manual are only a recommendation for an automatic lubrication system. They are not intended to replace any instructions provided in the OEM manuals. Always refer to the OEM's manuals for details on lubrication intervals.*

# Table of Contents

<b>Recommended Tools and Supplies</b> .....	<b>3</b>
<b>Installation</b> .....	<b>4</b>
Zerks and Grease Point Fittings .....	4
<b>System Layout and Lubrication Points</b> .....	<b>5</b>
CAT 22 Point Articulated Dump Truck Models 725 to 745 .....	5
<b>G3 Pump Mounting Bracket and Pressure Relief Valve Assembly</b> .....	<b>6</b>
<b>Assemble CSP Valves and Remote Fill Valve (If Equipped)</b> .....	<b>6</b>
<b>Install CSP Valves</b> .....	<b>7</b>
<b>Assemble Hose Fittings</b> .....	<b>8</b>
<b>Install G3 Pump</b> .....	<b>9</b>
<b>Install Power Cable</b> .....	<b>10</b>
<b>Assemble Bracket and Install the Controller (if equipped)</b> .....	<b>11</b>
<b>Hose Routing Guidelines</b> .....	<b>12</b>
<b>Wiring Guidelines</b> .....	<b>15</b>
G3 SP Pumps with Internal Controller, Feedback, and Manual Run Button Wiring Schematic .....	15
G3 Pro Pumps with Internal Controller and Manual Run Button Wiring Schematic . . . .	15
G3 Standard Pumps with External Controller, With and Without Feedback Wiring Schematic .....	16
<b>Programming</b> .....	<b>17</b>
<b>Fill with Grease</b> .....	<b>19</b>
Fill Pump Reservoir .....	19
Fill Valves and Hoses with Grease to Purge Air	19
<b>Test the System</b> .....	<b>20</b>
<b>Train the Operator</b> .....	<b>20</b>
Check List .....	20
<b>Troubleshooting</b> .....	<b>21</b>
<b>Parts</b> .....	<b>23</b>
Valve Kit .....	23
Pump Kits .....	24
Related Manuals .....	25
<b>California Proposition 65</b> .....	<b>26</b>

# Recommended Tools and Supplies

Tool	Size/Description	
	US	Metric
Combination wrench*	1/4 in. - 3/4 in.	6 mm - 20 mm
Socket, standard and deep well with ratchet*	3/8 in. - 3/4 in.	9.5 mm - 20 mm
Screwdrivers: standard and Phillips	1 short; 1 long	
Adjustable wrench	1 small; 1 medium	
High speed drill (corded or cordless)		
Drill bit - steel, high quality	5/16 in., 11/16 in.	
Center punch	fine point	
Pipe taper tap	1/8 in. npt	
Hammer		
Angle grinder		
Grinding disc	Heavy grade grinding disc	
Flap disc	60 - 80 grit	
Cutoff disc	High quality disc	
Cutting blade / knife	Razor blade cutting tool	
Standard pliers	Rubber handle	
Needle nose pliers	Rubber handle	
Side cut pliers (diagonal cutters)	Rubber handle	
Slip joint pliers	Rubber handle	
Locking pliers	Small or medium	
Wire stripper / crimper	General duty wire stripper / crimper	
Soldering iron	30 watt minimum	
Electrical solder		
Soldering flux		
Shrink tubing	Various sizes	
Electrical tape	Black, small roll	
Thread sealant	Liquid thread sealant such as Loctite® 656	
Multimeter / voltmeter	Must test DC/AC/Ohms	
Electrical connectors	Ring connectors (14 -18 gauge)	
Tape measure	Standard / metric	
Primer and paint	Color should match the equipment	
Documentation / writing implements	Small note pad, pen, pencil, marker	

\*Both US and Metric sizes of these tools are recommended.

Loctite® is a registered trademark of the Henkel Corporation.

All trademarks and registered trademarks used in this manual are for identification purposes only. All trademarks and registered trademarks are the property of their respective owners.

**NOTE:** When any of the following images are shown in the instructions it means that these components should be used during the installation to secure or protect parts.



P-Clamp

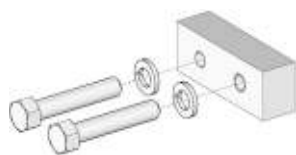

Weld Block  
and Bolts



Anchor Block



Zip Tie



Guarding

# Installation

Disconnect battery before installing the lubrication system. Inspect the machine and verify that the system design includes all lubrication points and meets the manufacturer's requirements.

## Zerks and Grease Point Fittings

1. Grease all zerk fittings (FIG. 1).



FIG. 1

2. Remove all grease zerks (FIG. 2).

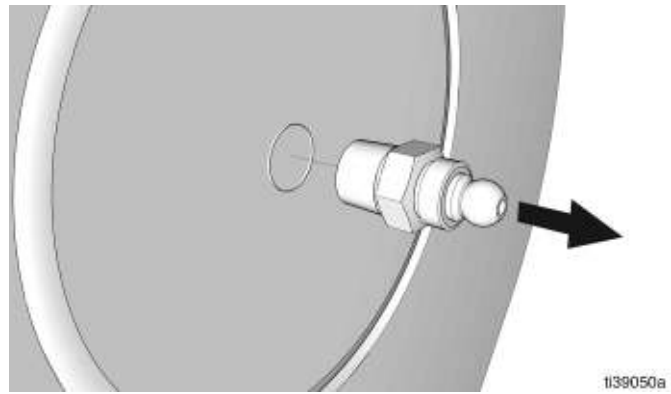

FIG. 2

3. The kit includes a variety of extenders, elbows, straight compression fittings, and elbow compression fittings (FIG. 3). Mix and match fittings and components supplied in the kit to replace the zerks.
4. Apply pipe sealant to fittings. To avoid contamination do not use PTFE tape on the fitting threads. If you must use PTFE tape, always ensure the first thread on the fitting is not taped and the tape is applied precisely.

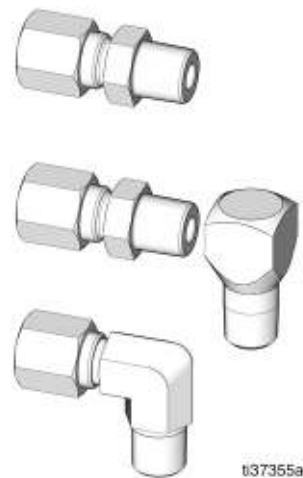

FIG. 3

# System Layout and Lubrication Points

## CAT 22 Point Articulated Dump Truck Models 725 to 745

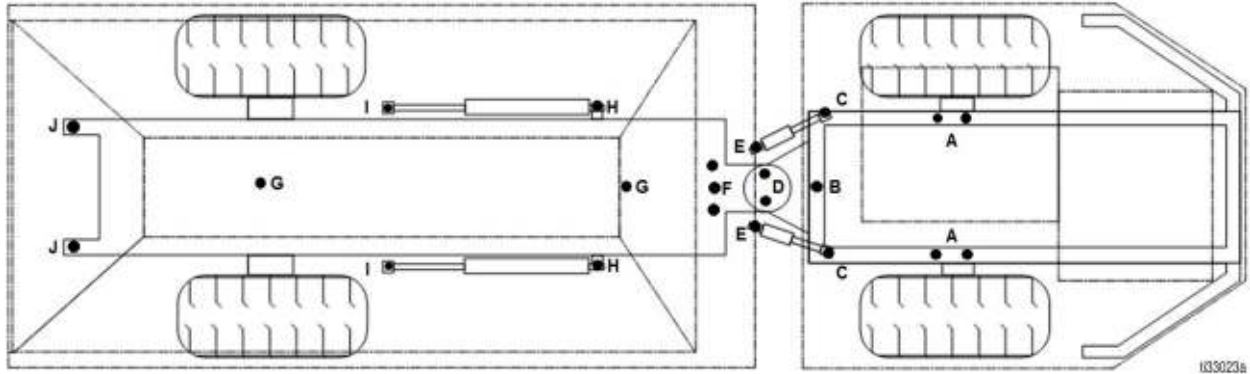
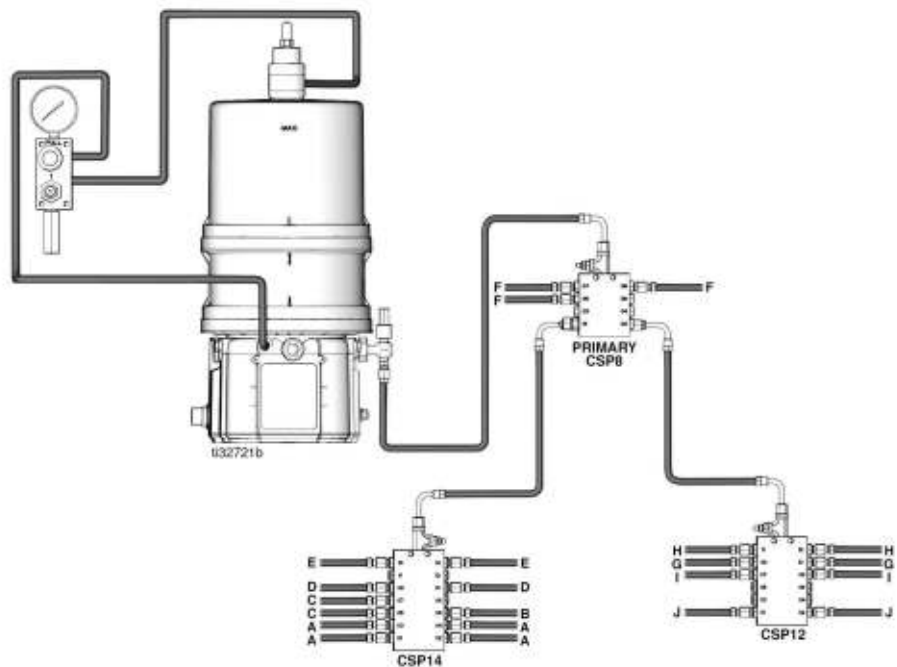

FIG. 4

Lube Point	Description
A	Front Suspension
B	Front Frame Pivot
C	Steering Cylinder
D	Center Pivot
E	Steering cylinder
F	Hitch Oscillation Bushing
G	Center and Rear Frame Pivot
H	Dump Body Cylinder Foot
I	Dump Body Cylinder Rod
J	Dump Body Pivot Rod



# G3 Pump Mounting Bracket and Pressure Relief Valve Assembly

Assemble and install the pressure relief valve and pump mounting bracket on the pump (FIG. 5). See the Graco G3 pump instruction manual for additional instructions. A complete list of related Graco instruction manuals is provided on page 25.

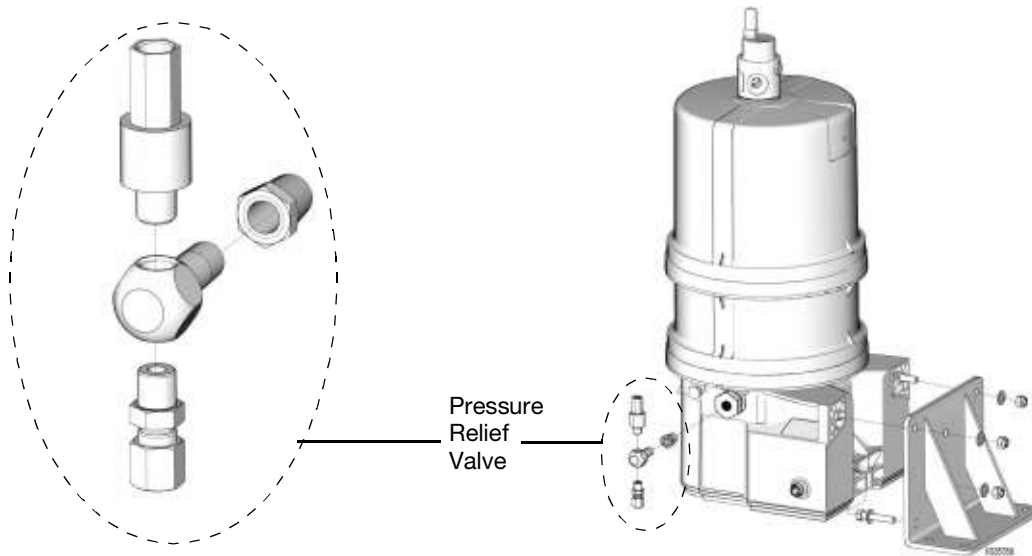

FIG. 5

# Assemble CSP Valves and Remote Fill Valve (if equipped)

The CSP primary valve assembly and the remote fill valve assembly shown in FIG. 6, are provided as a guide. Assemble the parts, as needed, to best accommodate the installation. See the Graco CSP Valve instruction manual for instructions. A complete list of related Graco instruction manuals is provided on page 25.

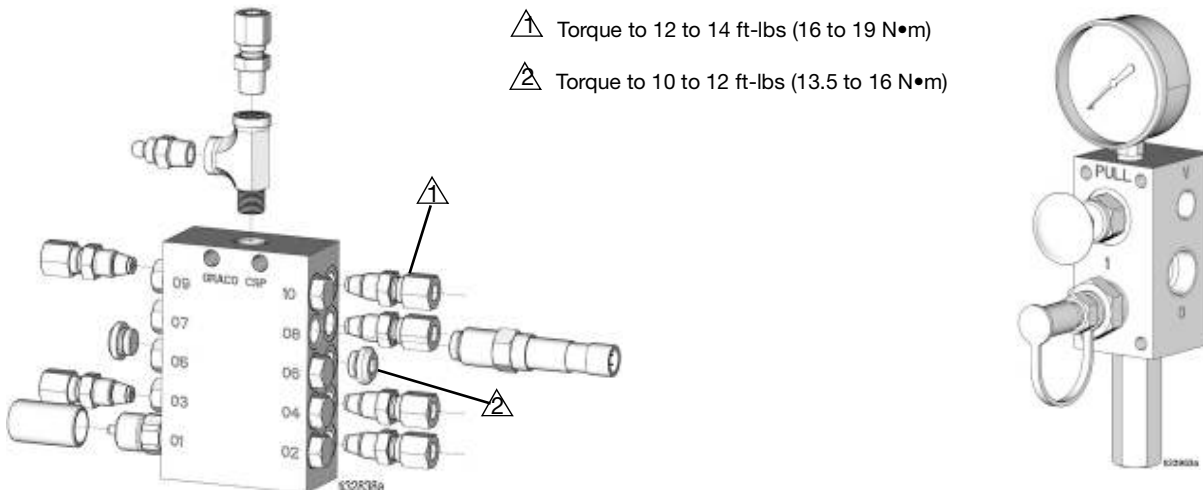

FIG. 6

# Install CSP Valves

Use supplied weld block and bolts to install the CSP valves on the equipment. Refer to FIG. 7 and FIG. 9 for recommended installation locations for the valves. Additional hardware may be required when mounting to sheet metal.

**NOTE:** If using a proximity switch to monitor the system:

- Route the proximity cable to the G3 SP pump mounting location.
- Route the proximity cable under the cab of the Articulated Dump Truck when using a GLC2200 controller.

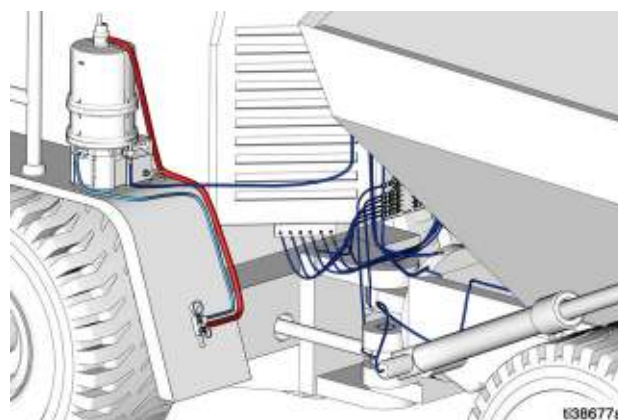
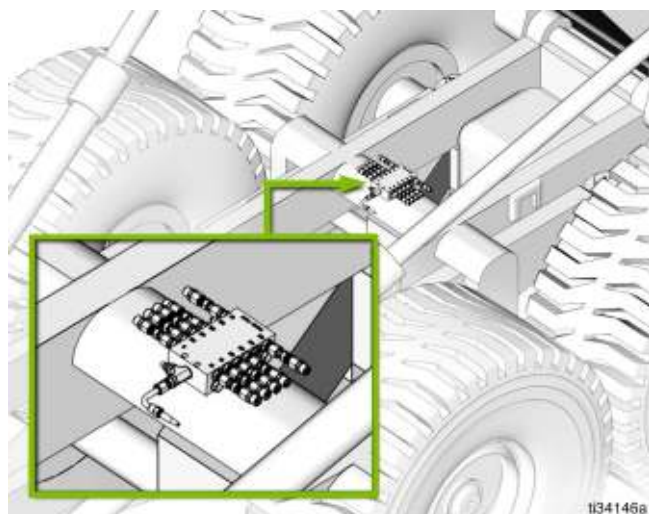
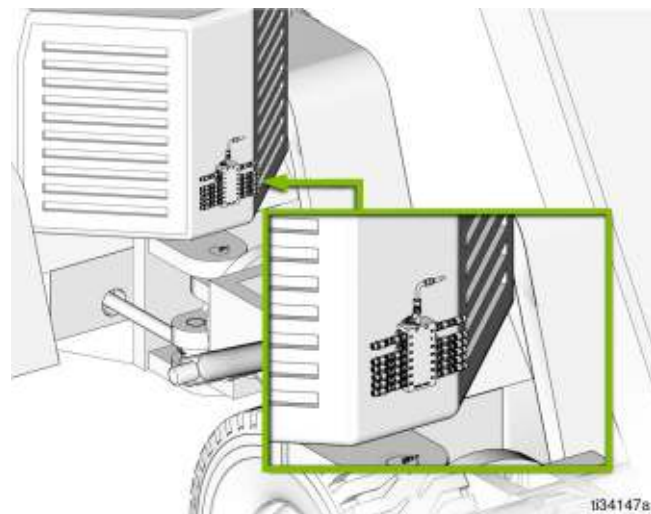
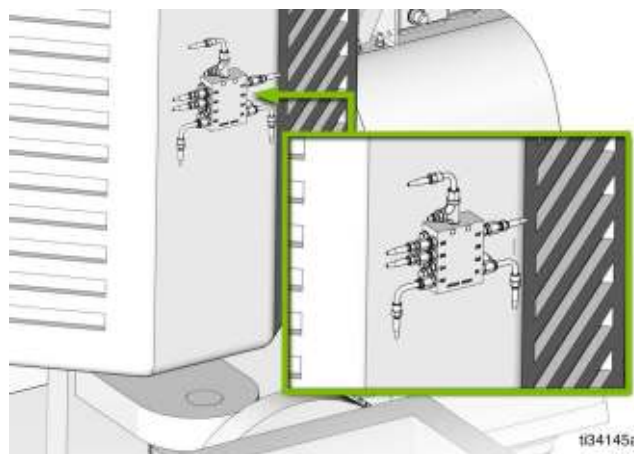

## Assemble Hose Fittings

The hoses included in the kit require assembly prior to installation. The two piece connection fittings must be installed to the end of the hose. For detailed instructions see manual 3A3159.

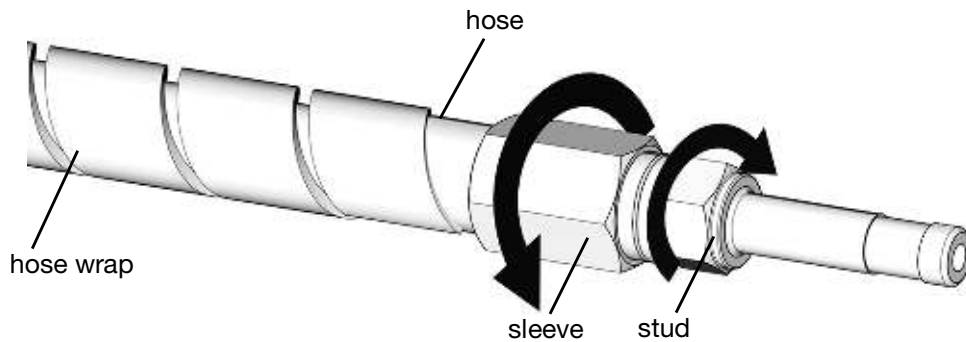

**FIG. 11**

**NOTE:** Steps 1-7 refer to FIG. 11.

1. Wrap or slide the hose wrap over the end of the cut-to-length hose until the entire length of the hose is encased in the hose wrap.
2. Trim the hose wrap, leaving approximately 1 in. of the hose end unwrapped.
3. Remove the stud and sleeve from their package and disassemble the two pieces.
4. Lubricate the sleeve threads and the hose inside diameter.
5. Install the sleeve onto the end of the hose by rotating it counter-clockwise until seated.
6. Back off 1/4 turn. This allows enough space for the stud to be connected.
7. Thread the stud clockwise into the sleeve until the sleeve nearly bottoms out against the stud shoulder.

### **NOTICE**

Do not over-tighten the fittings during the final assembly. After the two fittings are securely connected, stop tightening. Over-tightening can damage the fittings and a new hose assembly will need to be made.

The sleeve should be firm when tightening but not difficult to install. If the sleeve is difficult to install, check the hose for proper lubrication. Reapply lubricant as needed. Installation without proper lubrication can cause damage to the core tube.

8. Repeat Steps 1-7 for all hose assemblies.



# Install G3 Pump

## NOTICE

Never install pump directly to the cab. Do not drill holes or weld on any part of the cab. Drilling or welding on the cab will likely void the cab certification for Roll Over Protective Structures (ROPS) and Falling Object Protective Structures (FOPS).

Install the pump in a protected area near the cab. The installation location should have ample space around the pump to allow for the hoses, cables, and a relief valve.

- The deck plate that surrounds the cab is the preferred installation location (FIG. 12). The deck plate is a non-critical component and drilling through the deck plate is generally acceptable by most manufacturers. However, if this location is not acceptable due to durability or space constraints, identify an alternate location around the cab such as below the ladder, the back of the front fenders, or on the rear frame.
- A custom pump mounting bracket may be required if the preferred or alternative locations (referenced above) are not acceptable for mounting the pump.

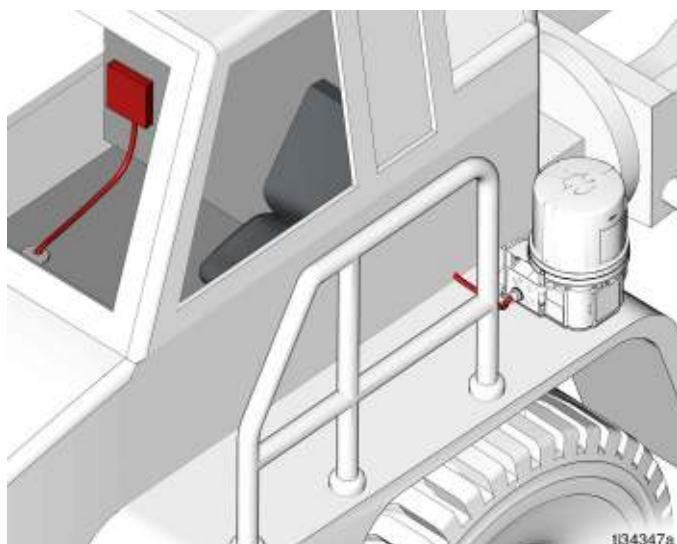

**Optional Pump Mounting**

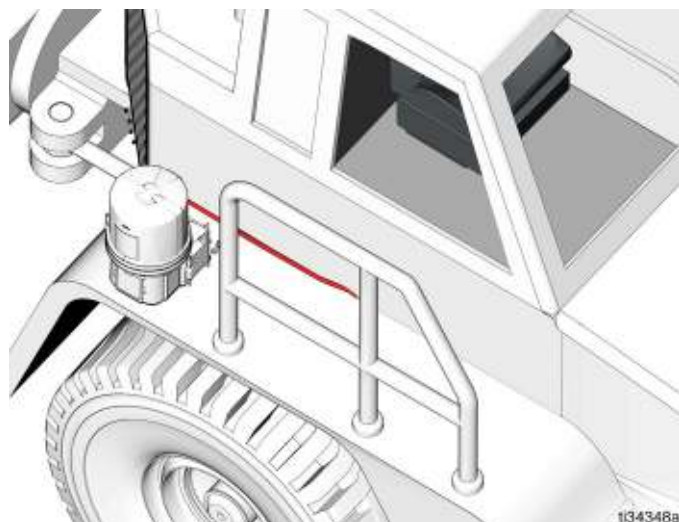

**FIG. 12**



# Install Power Cable

1. Route the power cable from the pump through the body of the machine and under the cab to protect it from the environment and to aid in wiring into the cab. For installations utilizing a proximity switch and a controller, route the prox cable along the same path as the power cable (FIG. 13).

**NOTE:** If using a G3 SP pump, route the prox cable directly to the pump and connect it to the supplied M12 connector.

2. Route the power cable into the cab through the rubber grommet located under the floor mat (FIG. 13).

**NOTE:**

- If the pump uses a remote manual run button with a 5-wire CPC cable, route the cable to the manual run button. See **Wiring Guidelines**, page 15.
- If the pump uses a controller, route the pump power cable into the cab, toward the fuse panel (FIG. 14). See **Wiring Guidelines**, page 15.

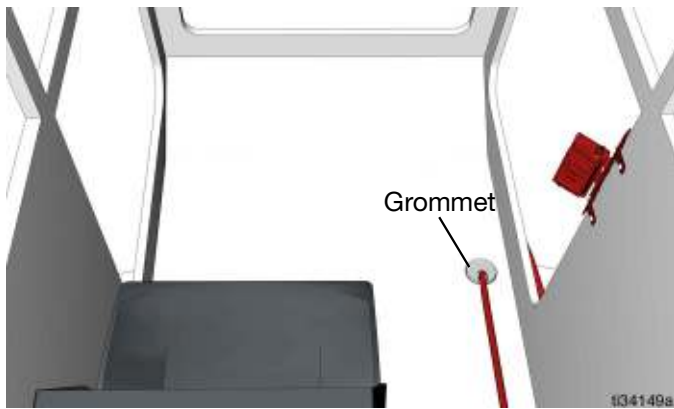

FIG. 13

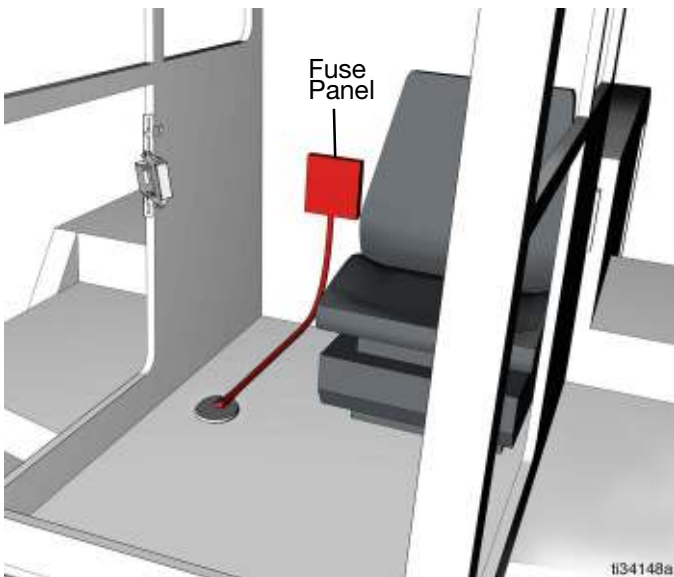
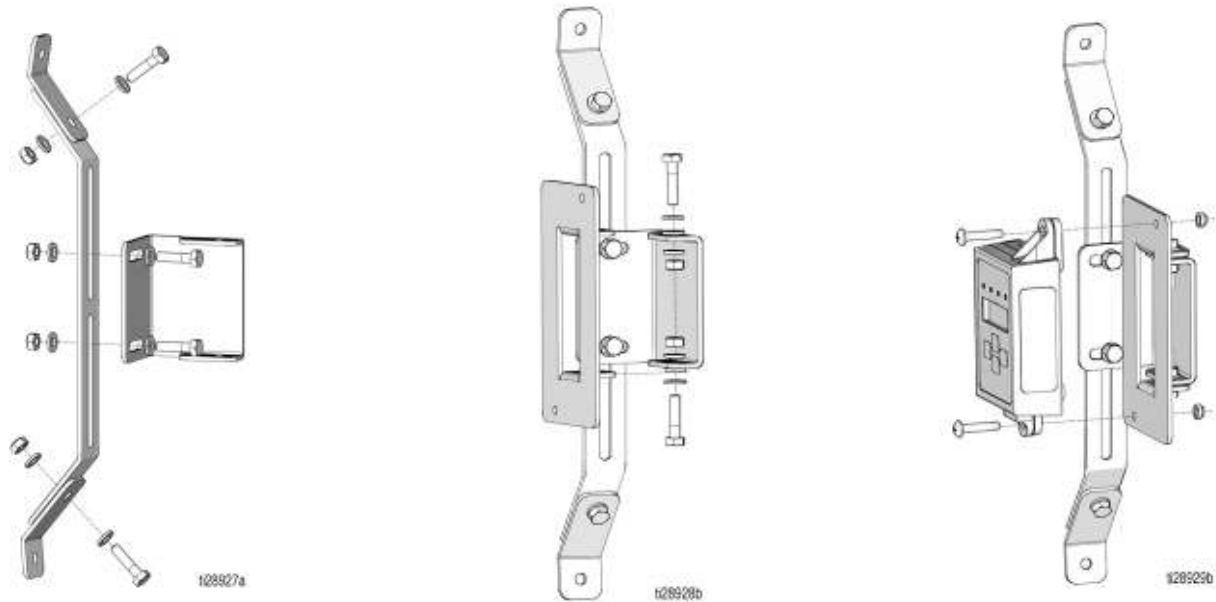

FIG. 14



# Assemble Bracket and Install the Controller (if equipped)

**NOTE:** All parts included in the mounting bracket kit may not be required for the installation. The bracket assembly shown in FIG. 15 is provided as a guide. The bracket is designed to be assembled in several configurations. Assemble the parts as needed to best accommodate the installation.



**FIG. 15**

1. Assemble the controller mounting bracket.

**NOTE:** FIG. 15 is only provided as a guide. Parts can be rotated to best suit the installation location and to provide optimal orientation for operator access inside the cab.

2. Attach the controller to the bracket using the hardware provided in the kit.
3. Install the bracket inside the cab using existing holes in the cab, and the hardware provided in the kit (FIG. 16).



**FIG. 16**

### NOTICE

Never install controller directly to the cab. Do not drill holes or weld on any part of the cab. Drilling or welding on the cab will likely void the cab certification for Roll Over Protective Structures (ROPS) and Falling Object Protective Structures (FOPS).

# Hose Routing Guidelines

## NOTICE

Never install valves directly to the cab. Do not drill holes or weld on any part of the cab. Drilling or welding on the cab will likely void the cab certification for Roll Over Protective Structures (ROPS) and Falling Object Protective Structures (FOPS).

- Identify the internal and external pivot points to ensure proper hose lengths are used. If hoses are too short they will bind and eventually break. If hoses are too long, they can easily snag on external debris or be pinched in the machine.
- Follow the existing hydraulic and electrical routing. This ensures that the lines are protected and routing is consistent with the OEM's existing hydraulic hose routing.
- Utilize existing grommets, supports or cut outs in the equipment's frame for access points. Routing the hoses through these areas keeps the hoses inside the machine and provides protection. This also provides a cleaner and more professional looking installation.
- Install hoses to ensure they move with the machine. Consider pivot, oscillation, extension, and pinch point areas on the equipment. Before cutting and securing hoses, have a qualified technician move the various parts of the machine to ensure proper routing is achieved.
- Connect hoses to divider valves.
- Use weld studs and p-clamps to secure hoses to the equipment. Use zip ties to secure the hoses together and to the equipment's existing hydraulic hoses.
- If possible, fill hoses with grease prior to installing on the equipment.
- See FIG. 17 through FIG. 21 for hose routing examples.

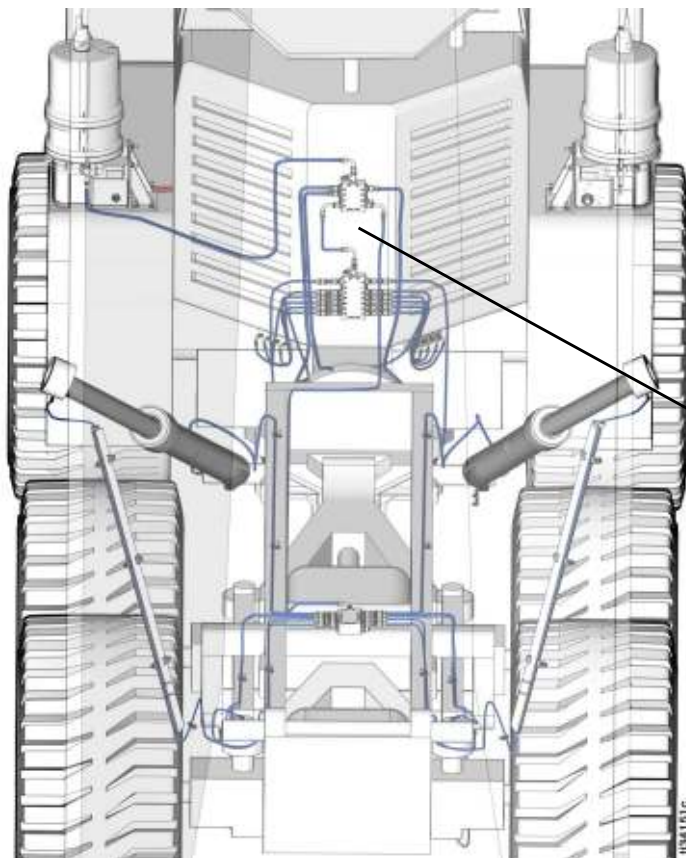

### Recommended Installation Components



Route hose to rear metering valve through the hydraulic loom, between the front and rear frame.

FIG. 17

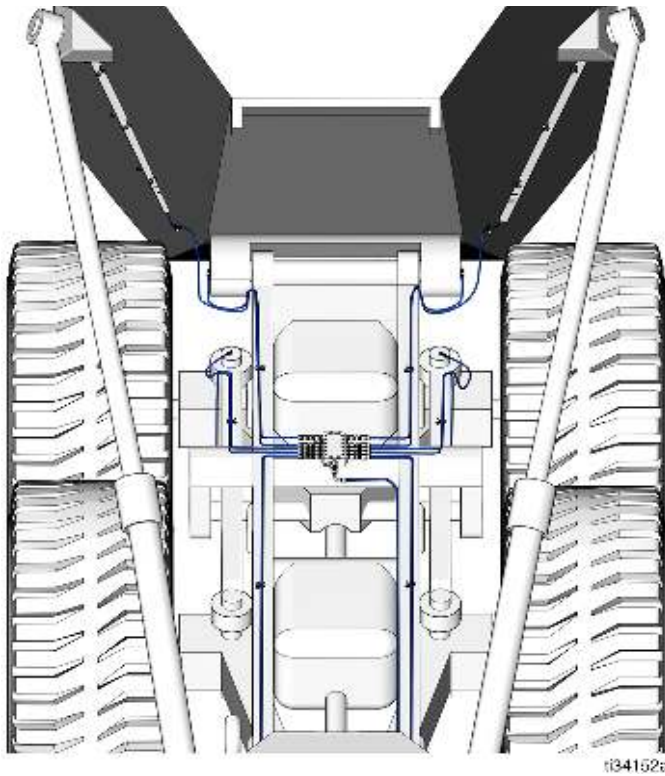

FIG. 18

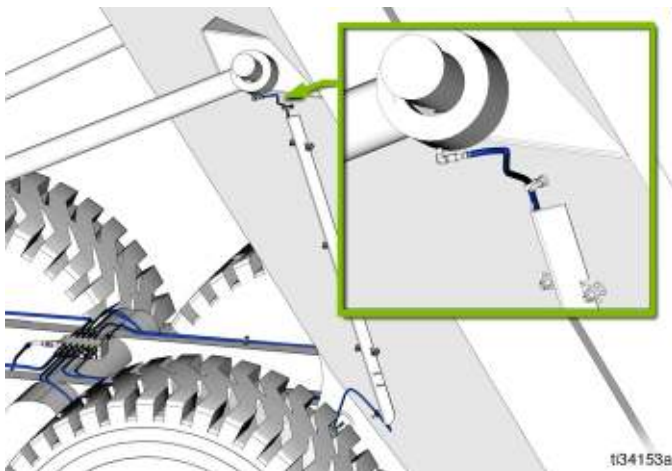
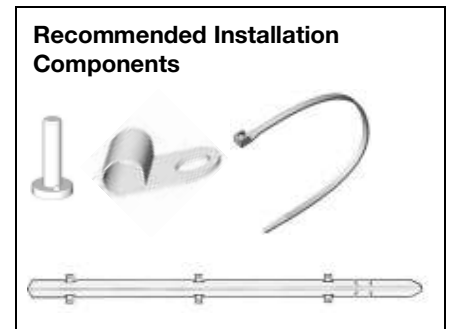
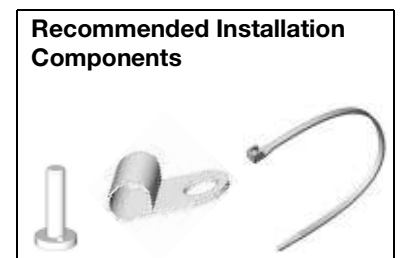

FIG. 19



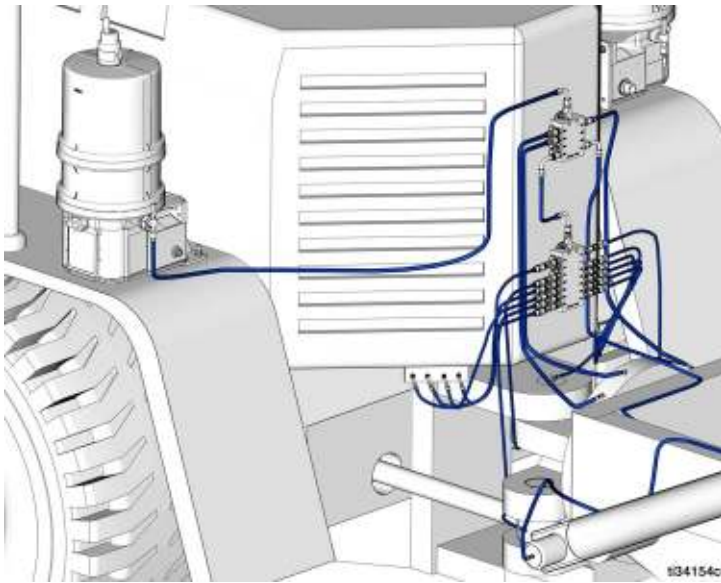

FIG. 20

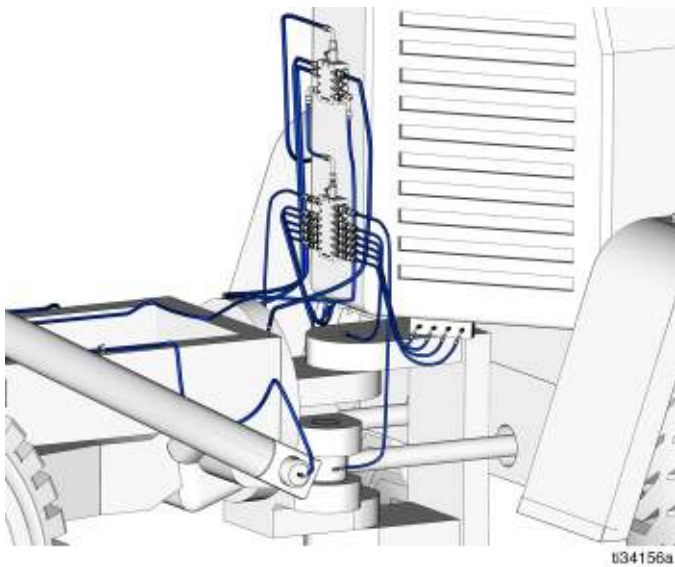
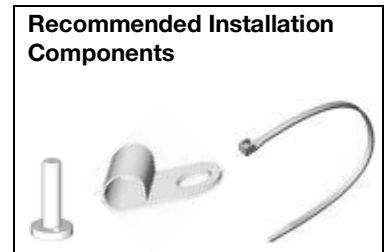

FIG. 21



# Wiring Guidelines

## G3 SP Pumps with Internal Controller, Feedback, and Manual Run Button Wiring Schematic (FIG. 22)

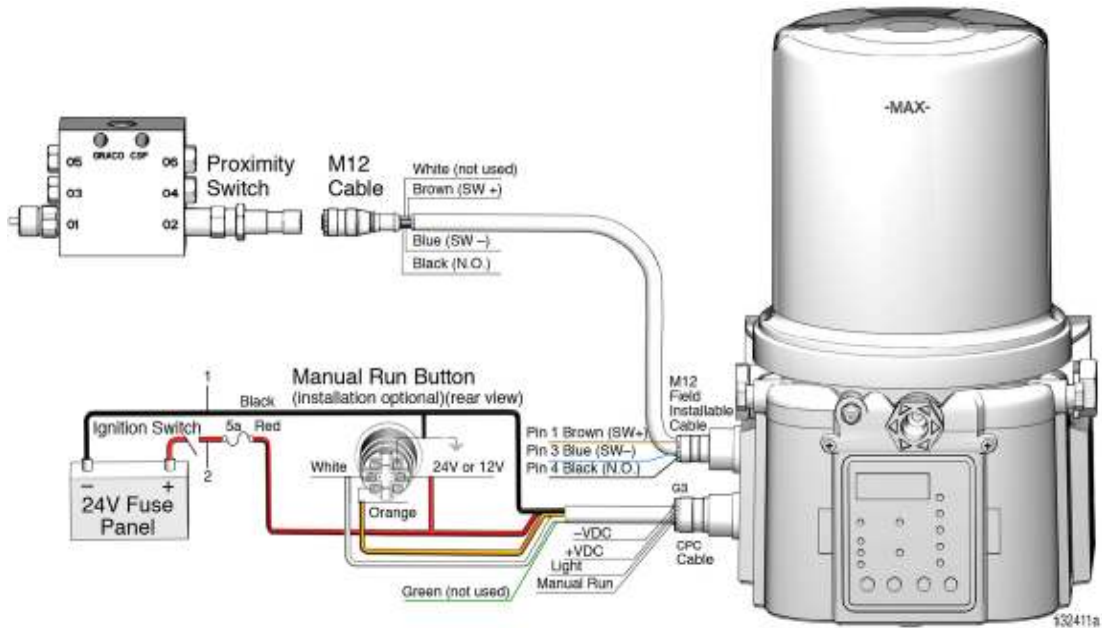

FIG. 22

## G3 Pro Pumps with Internal Controller and Manual Run Button Wiring Schematic (FIG. 23)

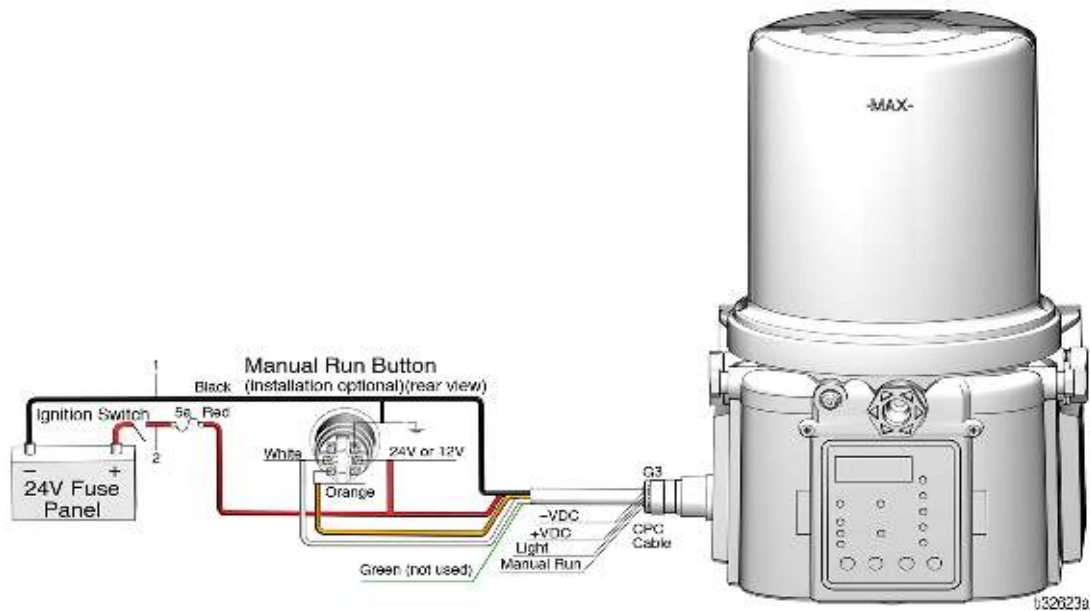

FIG. 23

## G3 Standard Pumps with External Controller, With and Without Feedback Wiring Schematic (FIG. 24)

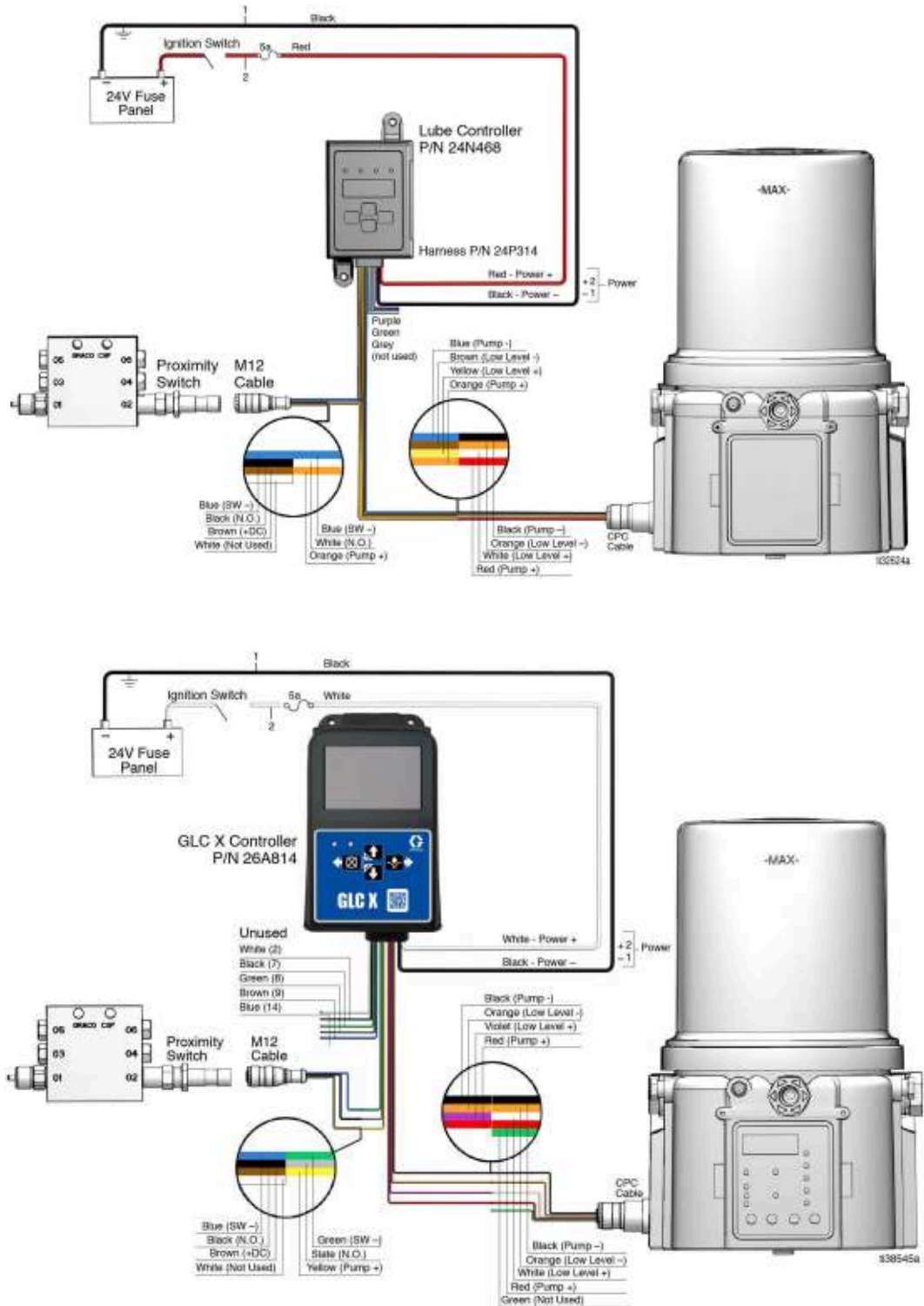

FIG. 24



# Programming (FIG. 25 - FIG. 28)

## G3 SP

### Example Settings:

Cycles: CY:15  
Off Time: 01:00

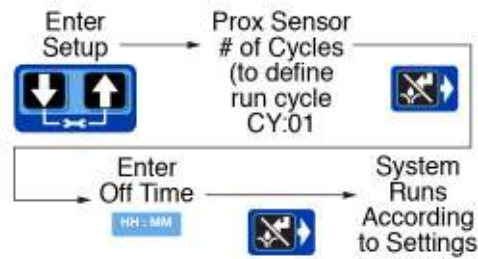

FIG. 25

## G3 Pro

### Example Settings:

On Time: 06:00 Min  
Off Time: 01:00 Min  
Prelube: Off  
or  
Prelube: On - 10:00

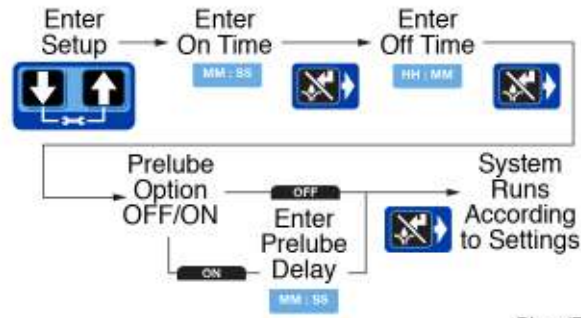

FIG. 26

## GLC2200

### Example Settings:

On: Cy  
Cycles: CY:15  
On Time: 10:00 Min  
Off Time: 01:00 Hour  
Low Level: LL:02

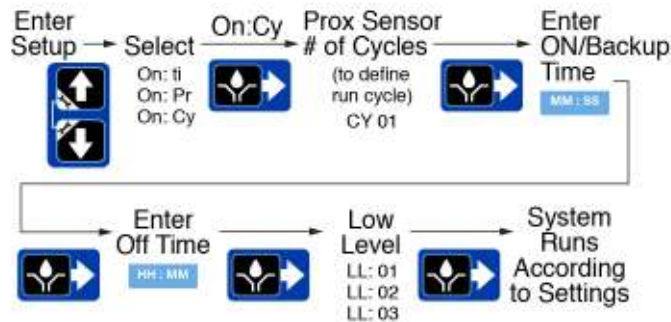

FIG. 27

# GLC X

## Example Settings:

- Cycles:** CY:08
- Time Out:** 10:00 Min
- Interval Time:** 01:00 Hour
- Prelube:** Off
- or**
- Prelube:** On - 10:00

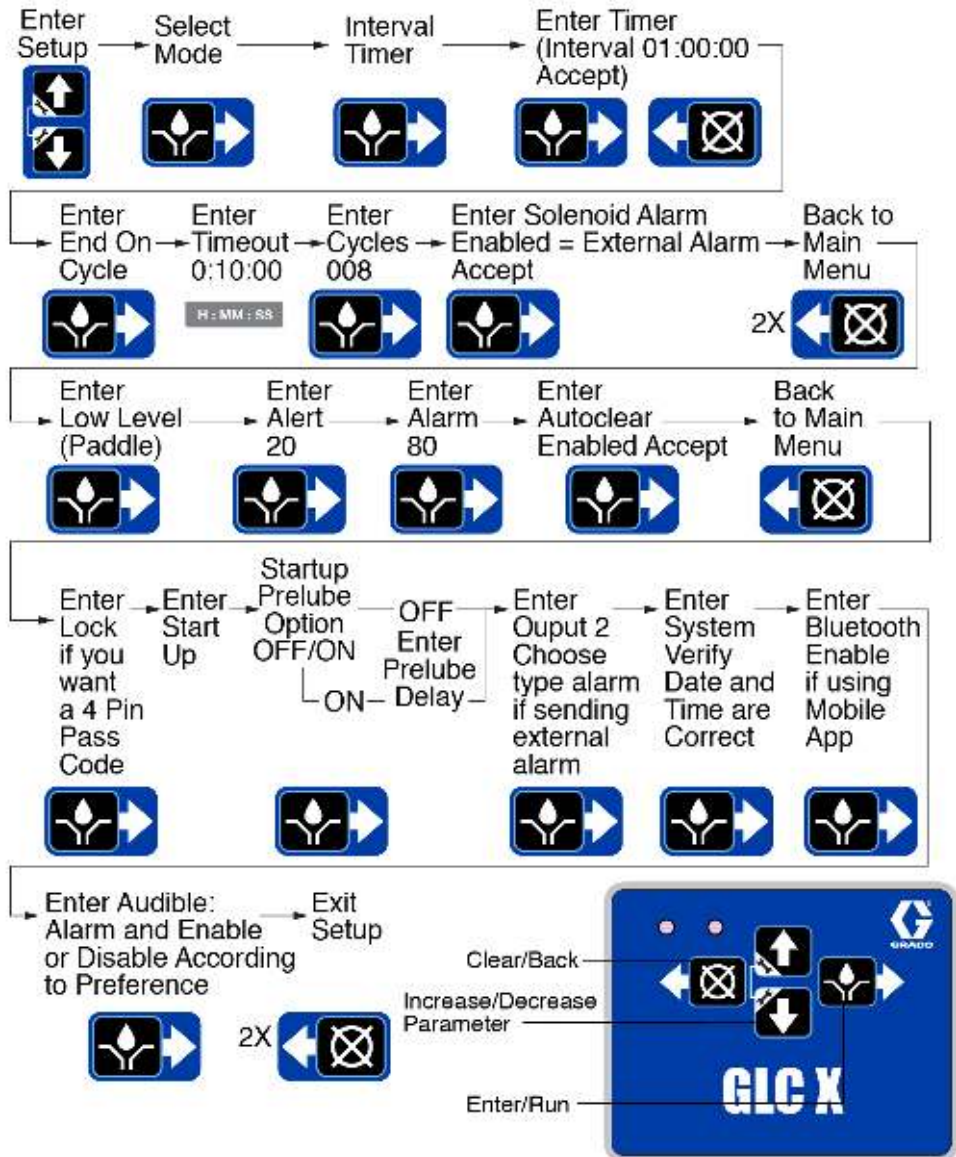

FIG. 28

# Fill with Grease

**NOTE:** Ensure dirt and/or debris does not get on the grease fitting or introduced into the system.

## Fill Pump Reservoir

- Fill the pump with grease through the grease zerk (FIG. 29).

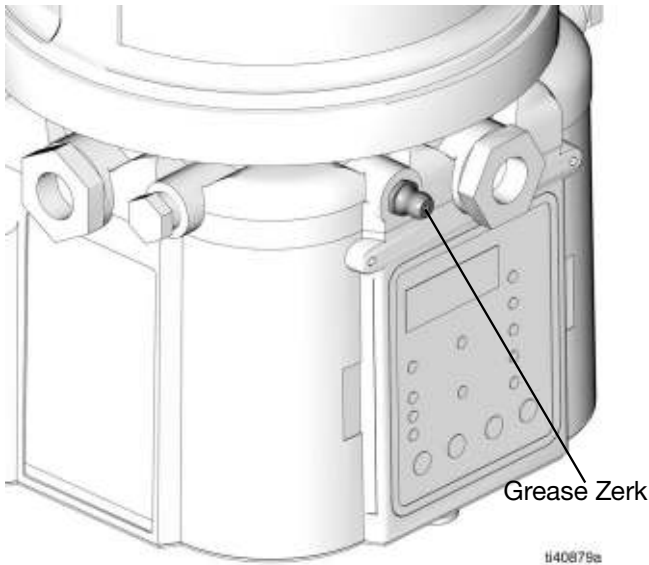

**FIG. 29**

- If using an Auto-Fill Shut Off pump, fill the remote fill manifold (FIG. 30).



**FIG. 30**

- Do not overfill the reservoir. See fill level on the front of the pump reservoir. Grease will flow out of the reservoir overflow located on the back of the pump if the reservoir is overfilled.

## Fill Valves and Hoses with Grease to Purge Air

An automatic lubrication system must be free of air to function properly.

- Connect a grease gun to the grease zerk on the CSP valves to fill them with grease (FIG. 31).

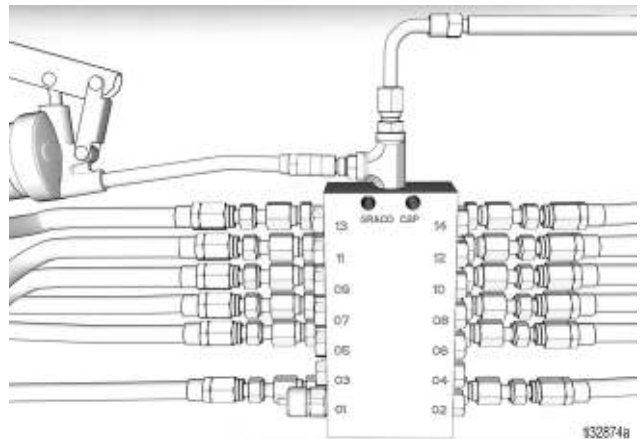

**FIG. 31**

- Use a waste container to capture excess grease from the grease hoses.
- Identify when hoses are filled and air is purged from the hose.

**NOTE:** It is helpful to have a colleague assist with this step. While one person fills the hoses with grease the second person monitors the grease hoses and bearing points and verify they are receiving grease and when they are filled.

- Tighten hoses to the pump and bearing points securely.

# Test the System

Before testing the system:

- Verify that the pump reservoir is filled with grease.
- Verify the valve and grease hoses are filled with grease and air is purged.
- Verify that all supply hoses are connected securely.
- Connect the power to battery. Turn key to ACC.
- Verify the G3 pump and the controller (when used) have power.
- Press the Manual Run button on the G3 pump or controller to run the lube system through several lube events and to ensure that all lube points are receiving grease.
- While the pump is running, walk around the equipment and inspect all pump, valves, hose fittings, and bearing point connections to confirm there are no leaks in the system.
- Articulate all working sections of the equipment to ensure there is sufficient hose length supplied to all lubrication points.
- Inspect the valve hose fittings and bearing point connections again, to confirm there are no leaks, the hoses are secure, and that all points are receiving grease.
- Adjust any fittings or connections that are leaking.
- If possible, put equipment into service and inspect the movement of the machine to verify there are no pinch points and that the equipment is functioning properly.
- After completing all of the testing, park the equipment in a safe and secure location. Disconnect the battery switch and ensure proper parking procedures are observed.
- Complete any final housekeeping activities such as cleaning the work area, ensuring that any potential grease spills have been cleaned up, and that all waste containers are disposed of properly.
- Perform a final walk around on the machine. Take photographs as needed for documentation or reference.

# Train the Operator

Train the operator on the features and day-to-day operation of the lubrication system.

## Check List

- How to know when the reservoir is empty.
- What to do when the reservoir is empty.
- How to know if the lube points are getting grease.
- Lubrication system inspection.
- Clearing faults on the pump or controller.

# Troubleshooting

Review the Troubleshooting Table below. For additional service, refer to the Graco Website, [www.Graco.com](http://www.Graco.com) and/or contact your Graco Distributor.

Problem	Cause	Solution
Pump does not power on.		Verify the equipment battery is connected and the key is in the ACC position. Check wiring to the G3 pump and GLC2200 controller is correct. See <b>Wiring Guidelines</b> , page 15.
GLC2200 controller or G3 pump is in alarm mode. System does not operate.		Hold down the fault clear button on the GLC2200 or G3 pump for 3 seconds to clear the fault and begin the OFF Time countdown.
GLC2200 controller is in fault mode and display shows ER:LL or G3 Pump is in fault mode and the LED next to the Low Level Fault is lit.		G3 Pump reservoir is empty and requires refilling. After reservoir is filled, press and hold the reset button on the GLC2200 or G3 pump for 3 seconds.
GLC2200 alarm sounding during machine operation.		To silence the alarm until service can be rendered, press the reset button for 1 second; then release the button. This will silence the alarm but maintain the lube system in alarm mode until serviced.
GLC2200 controller or G3 pump in fault mode. ER:Cy displays.		The lubrication system failed to complete a lube event in the time allowed to run. Verify controller is programmed correctly. In colder temperatures, it may be necessary to increase standard run time to complete the lube cycle.
		If the first solution does not correct the problem, run a manual cycle and check the pump relief valve for discharged grease. The grease pressure is at 4000 psi (27.58 MPa, 275.8 bar) when the relief valve discharges. If grease has discharged from the relief valve, a bearing may have stopped taking grease, a hose may be compromised, or the CSP valve may be clogged.
		Inspect CSP divider valve hoses for damage and/or leaks. Replace hoses if needed. If hoses are not compromised, use a manual grease gun to verify the valves are accepting grease.
		If the CSP valve fails to accept grease; the valve may be clogged and need to be replaced or the bearing point is refusing to accept grease. Repeat steps for remaining CSP valves until the blockage is found.
The CSP valves refuse to accept grease.		Verify that the CSP valves have not been over-torqued to their required specification. If they have been over-torqued, valve performance can be compromised. Adjust the valve assembly.

Problem	Cause	Solution
Bearings are not receiving enough grease.		Reduce the OFF Time on the controller. This will increase the frequency of the lube events and increase the amount of grease the bearings receive throughout the day. Alternative setting = 45 minutes = 30% increase, 40 minutes = 50% increase, 30 minutes = 100% increase.
GLC2200 controller or G3 pump will not run programmed time.		Verify you are programming the hours, minutes, and seconds correctly. Refer to the GLC2200 or G3 pump instruction manual.
There is a broken hose in the lubrication system.		Replace broken hose. See <b>Assemble Hose Fittings</b> , page 8. The original kit included extra hose and fittings. If you do not have spare hose and fittings to assemble a replacement hose, contact your Graco Distributor for assistance with ordering new parts.
GLC X display or LED does not come on.	Incorrect or loose wiring.	Refer to Installation.
	Input voltage is out of range.	Confirm that the power source is between 9 and 30 VDC.
	Tripped external fuse.	Confirm that none of the devices or wiring connected to the controller are causing a short circuit connection. If necessary, replace fuse.
GLC X pump is not running during lubrication event.	Incorrect or loose wiring.	Confirm current is being delivered to the pump during a lubrication event. Verify that your machine has been wired correctly. Refer to Installation.
	Controller output is incorrect.	Confirm output voltage (Pump Output +) from controller during lubrication event is correct (should be similar to input voltage).  If controller output voltage is never present, the device may need replacement.
GLC X reservoir runs out of grease quickly and unexpectedly	TEST MODE is engaged.	Turn off TEST MODE.
	There is a leak.	Check reservoir and lines for leaks.
GLC X always in low level	Review ground difference between the GLC X and the switch or sensor	Rewire if necessary.

# Parts

## Valve Kit with Guarding for Articulated Truck (26C127): includes one 26C159 and one 26C156

<b>26C159</b>		
<b>PN</b>	<b>Description</b>	<b>Quantity</b>
17S554	8.6 mm hose, 100 meters	1
123147	9 mm hose wrap, 10 meters	5
17L648	Hose stud sleeve	75
17R565	Hose stud straight	40
17R566	Hose stud 90-degree	35
17L550	CSP outlet 8.6 mm compression fitting	30
17L548	1/8 bspt x 6 mm compression fitting, straight	30
17L546	1/8 bspt x 6 mm compression fitting, 90-degree	30
17T780	1/8 npt x 6 mm compression fitting, straight	4
17T781	1/8 npt x 6 mm compression fitting, 90-degree	4
17K061	1/8 bspt x 1/8 90-degree elbow	15
17G422	1/8 bspt x 1/8 extension	15
17T782	1/4 npt x compression	1
15M045	1/4 npt short street elbow	1
24Z505	CSP8 w/indicator	1
24Z507	CSP12 w/indicator	1
24Z508	CSP14 w/indicator	1
17L651	CSP doubling plug	25
25N730	CSP weld bar kit	4
127513	P-clamp weld studs	22
557944	P-clamps	20
102040	1/4 - 20 nuts	28
17K063	Zip ties 100 ct.	1
555888	Grease Zerk	3
556419	CSP inlet tee	3
557969	Grease zerk cover	3

<b>26C156, Channel guarding kit, long</b>		
<b>PN</b>	<b>Description</b>	<b>Quantity</b>
17C976	Boom guarding	2
17D023	Boom guarding weld studs	12
100023	Guarding washers	12
101566	Guarding lock nuts	12

## Pump Kits

### G3 Standard with GLC 2200

26C130 (2L), 26C131 (4L), 26C132 (9L), 132871 (4L w/AFSO), 132872 (8L w/AFSO)

### G3 Standard with GLC X

132868 (2L), 132869 (4L), 132870 (8L), 132873 (4L w/AFSO), 132874 (8L w/AFSO)

### G3 Pro

23C133 (2L), 26C134 (4L), 26C135 (8L), 132875 (4L w/AFSO), 132876 (8L w/AFSO)

### G3 SP

26C136 (2L), 26C137 (4L), 26C138 (8L)

### G3 Max

132877 (4L w/AFSO), 132878 (8L w/AFSO)

PN	Description	Models/Quantity				
		G3 Std. w/ 2200	G3 Std. w/ GLCX	G3 Pro	G3 SP	G3 Max
Varies	G3 Pump	1	1	1	1	1
571031	Manual run button	--	--	1	1	1
17V033	10 ft. Extra wire (power/ground)	--	--	1	1	1
24N468	GLC2200	1	--	--	--	--
24W981	GLC2200 10 ft. Cable	1	1	--	--	--
26A814	GLC X controller	--	1	--	--	--
26A882	GLC X Cable	--	1	--	--	--
17G007	Controller mounting bracket	1	1	--	--	--
17D688	Add-a-Fuse	1	1	1	1	1
557264	Fuse 5amp ATO/ATC	1	1	1	1	1
131944	Fuse holder	1	1	1	1	1
131945	Fuse 5amp atm	1	1	1	1	1
164815	Branch tee outlet fitting 1/8	1	1	1	1	1
556402	Reducer bushing 1/4 x 1/8	1	1	1	1	1
115122	4000 PSI relief valve	1	1	1	1	1
125910	Pump mount bracket	1	1	1	1	1
17L879	CSP Prox switch	1	1	--	1	1
25M604	CSP Prox switch cable	1	1	--	1	1
124594	M12 field installable end	--	--	--	1	1
102258	Large ground ring connector	2	2	2	2	2
106595	Small ground ring connector	2	2	2	2	2
124227	Pump mounting bolts	4	4	4	4	4
111040	Pump mounting nuts	4	4	4	4	4
100527	Pump mounting washers	4	4	4	4	4
additional parts with AFSO option						
77X542	AFSO remote fill valve	1	1	1	--	1
15M045	1/4 npt street elbow	1	1	1	--	1
556762	1/4 npt x -4 JIC straight	2	2	2	--	2
128845	3/8 npt x -4 JIC straight	2	2	2	--	2
128572	1/4 in. Hose	1	1	1	--	1
129332	Remote fill mounting bolts	4	4	4	--	4
102040	Remote fill mounting nuts	4	4	4	--	4
128563	Hose end 1/4 hose -4 ftg	4	4	4	--	4
16T854	VV cover plug	--	--	--	--	1



## Related Manuals

Manual No.	Title
<b>332291</b>	G3 Standard Pump
<b>332298</b>	G3 Pro Pump
<b>3A4676</b>	G3 SP Pump
<b>3A5028</b>	G3 Illuminated Remote Run Button
<b>3A2960</b>	GLC2200 Controller
<b>3A3159</b>	Instructions for Installing a Field Attachable/Reusable Hose Fitting
<b>3A3995</b>	CSP Valve
<b>3A7031</b>	GLCX Lubrication Controller
<b>333393</b>	Fill Valve Instructions

# California Proposition 65

## CALIFORNIA RESIDENTS

 **WARNING:** Cancer and reproductive harm – [www.P65warnings.ca.gov](http://www.P65warnings.ca.gov).

*All written and visual data contained in this document reflects the latest product information available at the time of publication.  
Graco reserves the right to make changes at any time without notice.*

*For patent information, see [www.graco.com/patents](http://www.graco.com/patents).*

Original information. This manual contains English. MM 333548

Graco Headquarters: Minneapolis

**International Offices:** Belgium, China, Japan, Korea

**GRACO INC. AND SUBSIDIARIES • P.O. BOX 1441 • MINNEAPOLIS MN 55440-1441 • USA**  
**Copyright 2018, Graco Inc. All Graco manufacturing locations are registered to ISO 9001.**

[www.graco.com](http://www.graco.com)

Revised, March 2022